

Exit Twist Roller Guides RTC-RS 1 / 3 / 5

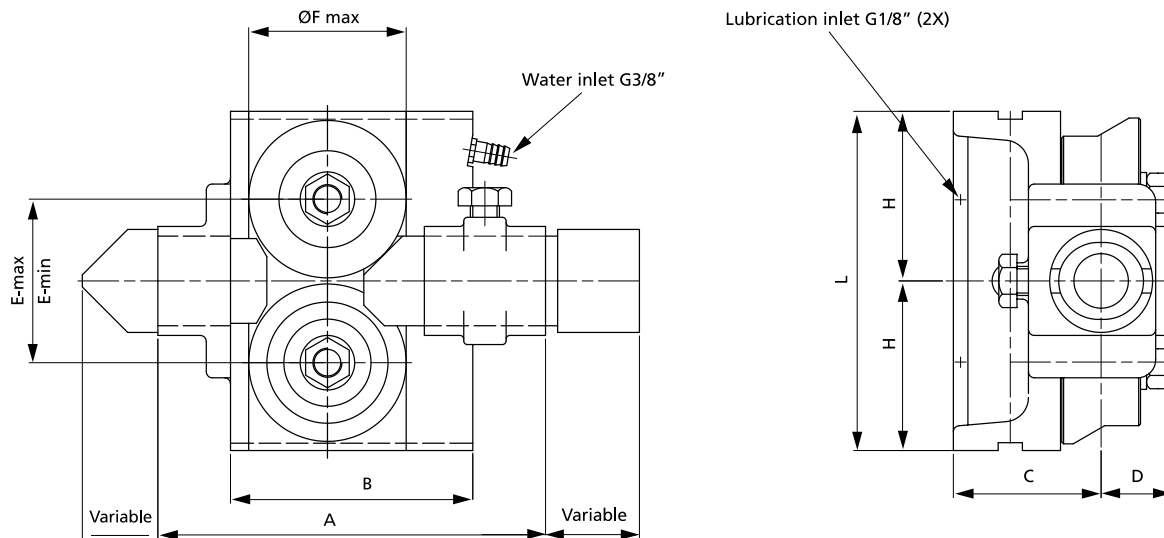

RTC	A	B	C	D	E _{max} /E _{min}	F max	H	L	Weight
1	235	165	81	34	90/70	Ø95	95	190	13
3	290	175	95	40,5	107/83	Ø110	110	220	19
5	320	200	122	59	137/113	Ø140	140	280	35

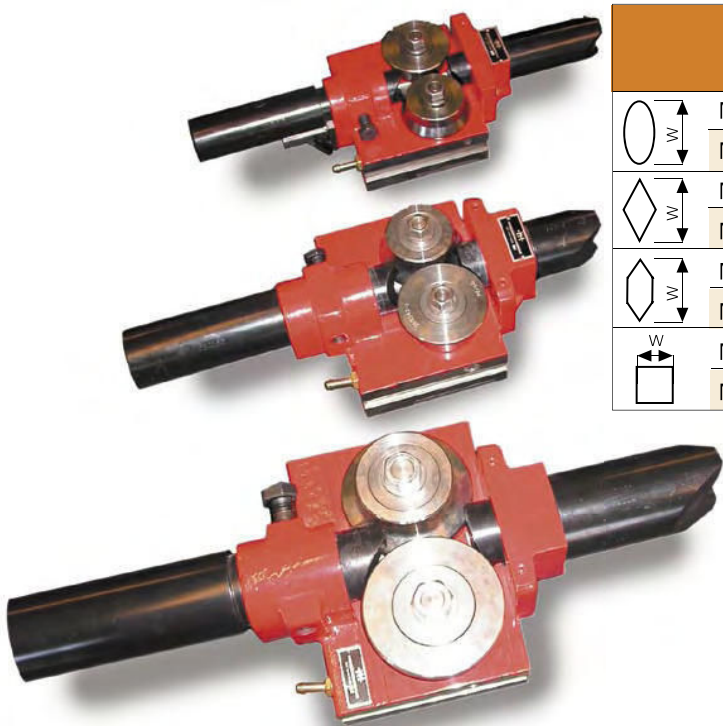

		RTC			RTC		RTC		
		1	3	5	7	10	12	15	18
	Min	8	15	23	36	50	68	90	120
	Max	27	40	56	80	105	140	180	200
	Min	8	15	23	36	50	68	90	120
	Max	27	40	56	80	105	140	180	200
	Min	8	15	23	36	50	68	90	120
	Max	27	40	56	80	105	140	180	200
	Min		8	15	25	35	48	65	85
	Max		20	28	40	55	73	95	125



Exit Twist Roller Guides RTC-RS 7/10

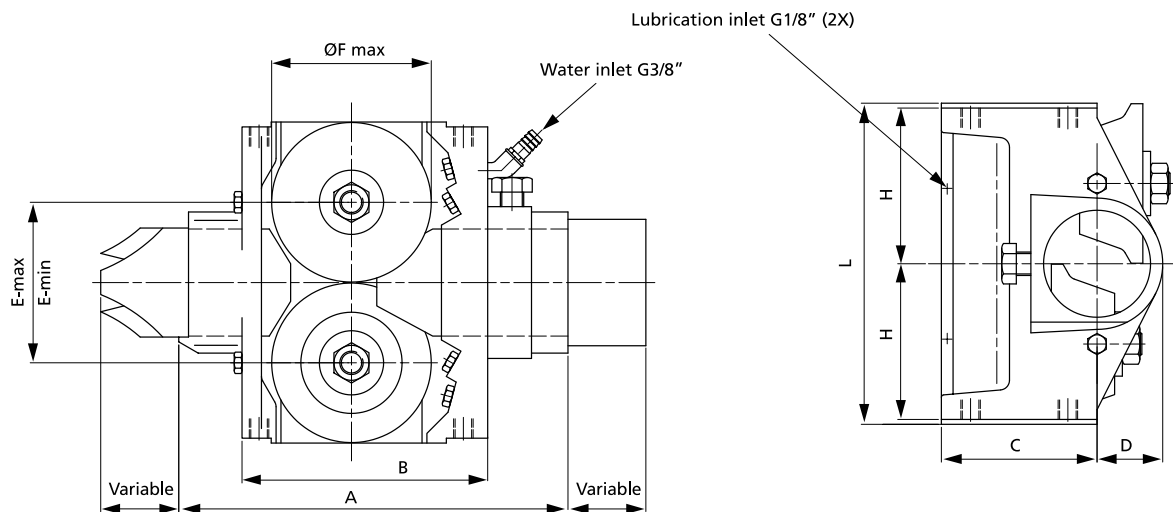

RTC	A	B	C	D	E _{max} /E _{min}	F max	H	L	Weight
7	390	252,5	160	75	165/145	Ø170	160	330	74
10	460	305	202,5	90	210/190	Ø210	195	410	150

Exit Twist Roller Guides RTC-RS 12/15/18

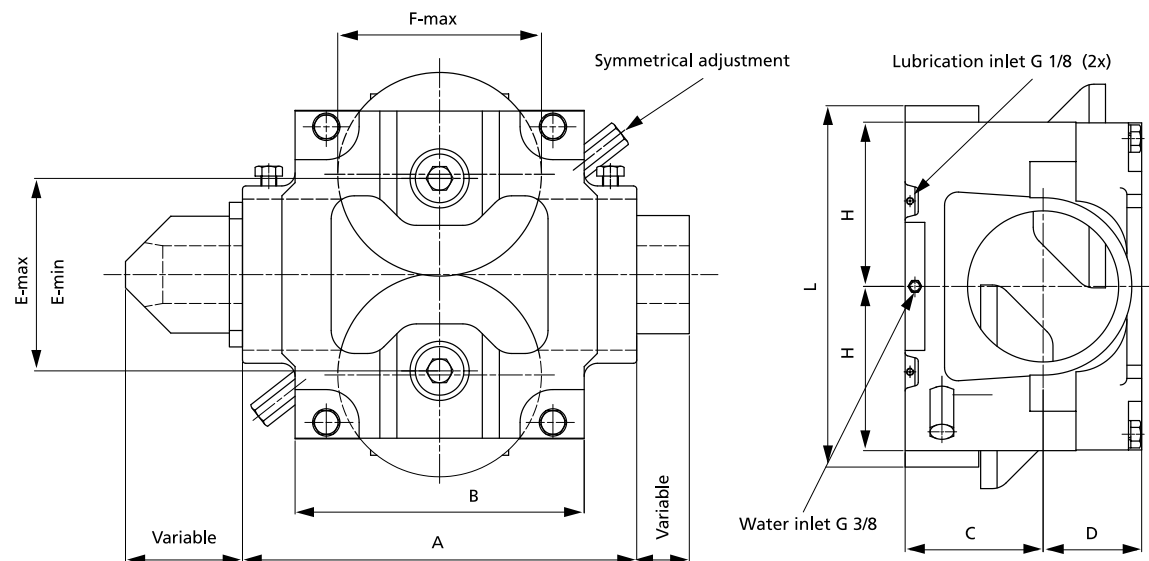

RTC	A	B	C	D	E _{max} /E _{min}	F max	H	L	Weight
12	490	360	185	123,5	248,5/228,5	Ø250	210	450	180
15	600	440	210	150	305,5/282	Ø310	250	550	315
18	800	600	265	170	376/345	Ø395	335	720	790



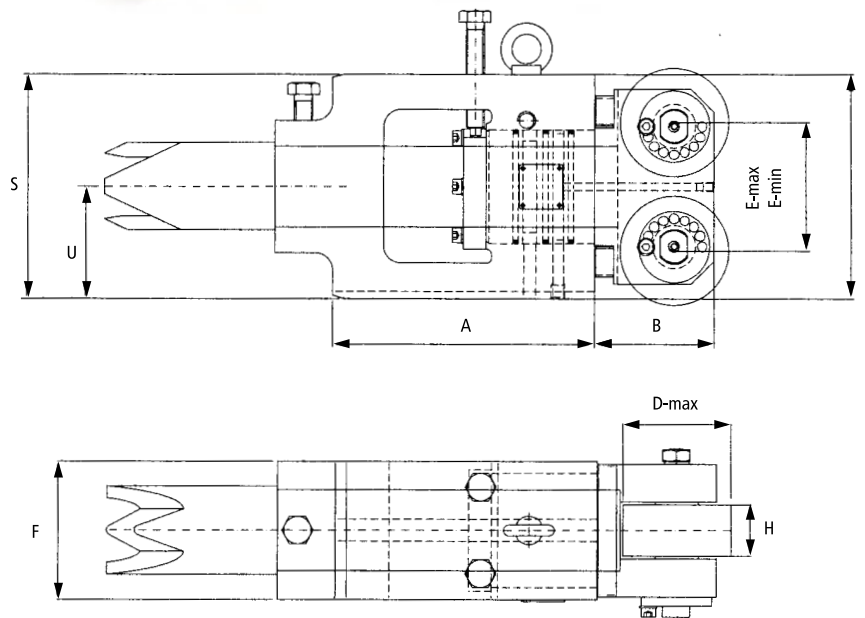
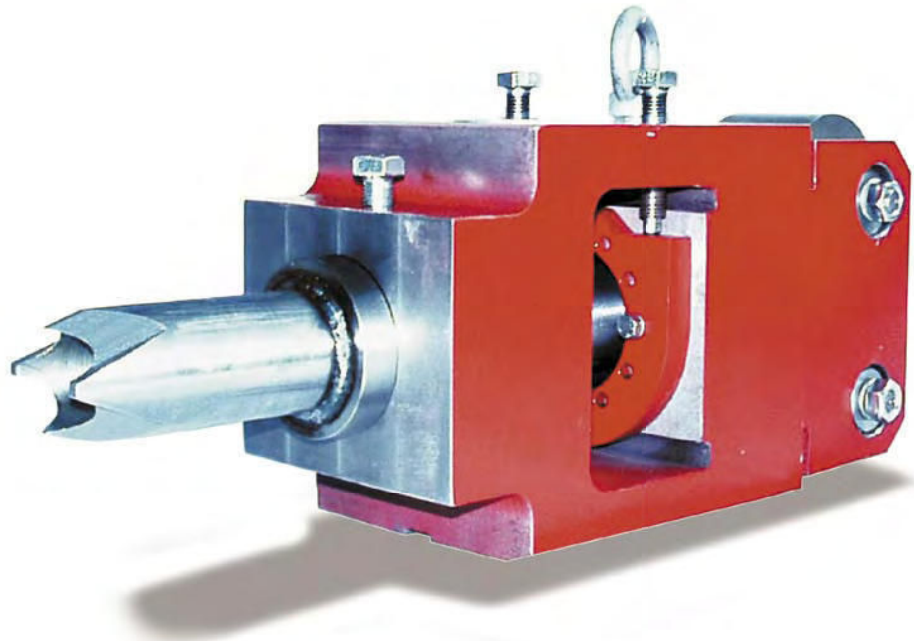

Type	CTR-01	CTR-02	CTR-03
Max Thickness	35	45	55
A	280	280	360
B	105	125	170
D Max	95	110	140
E Max	112	133	165
E-min	98	117	149
F	120	165	250
H	45	75	120
S	195	220	310
T	170	200	255
U	97,5	110	155

